

12v solar energy storage cabinet lithium battery inverter battery assembly



12v solar energy storage cabinet lithium battery inverter battery as



Solar Battery Enclosure

You can also check out our solar inverter battery cabinets, BBA solar battery enclosures, underground solar battery boxes, and more products specifically made for alternative energy storage and protection.

Atlas Expandable Energy Storage Cabinet

The expandable stackable Lithium Battery Storage Cabinets makes adding multiple Batteries or additional Inverters to your Energy Storage Solution quick, attractive and super simple. This ...

ESS



Large Battery & Inverter Cabinet Enclosure for up to 12 x 19? Battery

ALL12+ is the largest option in the Wescor battery & equipment cabinet range and houses up to 12 x 19? 3RU rackmounted battery modules and associated power conversion equipment. Save time on-site ...

15kW / 35kWh Hybrid Solar System Integrated Energy Storage Cabinet

The BSLBATT PowerNest LV35 hybrid solar energy system is a versatile solution tailored for diverse energy storage applications. Equipped with a robust 15kW hybrid inverter and 35kWh ...



Solar Energy Storage Battery Assembly: A Step-by-Step Guide for ...

With global solar capacity projected to grow at a 12% CAGR through 2030 [9], understanding solar energy storage battery assembly isn't just for engineers anymore. Whether ...

LiHub , HAIKAI Energy

HAIKAI LiHub All-in-One Industrial ESS (Energy Storage System) is a powerful and compact lithium battery solution designed for reliable energy management. Each LiHub cabinet integrates inverter ...

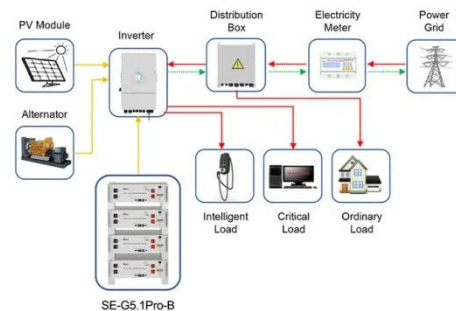

Application scenarios of energy storage battery products

ESS Solar Energy Storage Battery Cabinet 215kwh 430kwh 1MWh ...

Namkoo NKB Series 215kwh commercial & industrial energy storage system adopts the all in one design concept. The

cabinet is integrated with battery management system (BMS),energy ...



Solar Battery Storage Cabinet

The LZY solar battery storage cabinet is a tailor-made energy storage device for storing electricity generated through solar systems. They assure perfect energy management to continue power ...



Lithium Battery Storage Cabinets

Discover lithium battery storage cabinets with LiFePO4 cells, IP54-IP65 protection, CE certification, and 6000+ cycles for reliable battery store solutions.

Solar Energy Lithium Battery and Inverter Storage Cabinet Solution

Discover AZE's LFP battery storage cabinet systems, designed to store inverter, BMS, EMS, LFP batteries, modular, Expandable and

advanced safety features, the ESS cabinet serves as a ...



Contact Us

For catalog requests, pricing, or partnerships, please visit:
<https://scelto.co.za>

